

SERVICE
LIGHT LIFTING
INDUSTRIAL CRANES
PROCESS CRANES
PORT CRANES
LIFT TRUCKS

XA ALUMINIUM LIGHT CRANE SYSTEM

KONECRANES[®]
Lifting Businesses[™]

XA ALUMINIUM LIGHT CRANE SYSTEM



EFFICIENCY TO YOUR MANUFACTURING PROCESSES!

Light crane systems extend Konecranes' wide range of lifting solutions to work in cells and for lighter material handling needs.

Product range covers aluminium systems, from monorails to single and double girder cranes, up to a load of 2000 kg.

Light crane systems with aluminium profile have been newly developed to meet and exceed the specific requirements of demanding industries, such as the automotive sector. Modular design combined with light weight, high structural stiffness, small rolling resistance and very silent use allow wide scale of standard and tailor-made solutions, to any modern lifting demand.

Product Programme:

- > Most comprehensive aluminium rail programme in the industry, up to 2000 kg
- > Versatile configurations available including single and double girder cranes and basic monorail solutions

XA cranes are delivered with following standard features:

- > XA profiles cut in length
- > Profiles with bolt connections, no welding required
- > Durable anodized aluminium surface without painting required
- > Push trolleys for bridge and hoist

XA system can also be selected with following options:

- > Motorized trolley for bridge and/or trolley, with integrated frequency control
- > Variety of suspensions
- > Variety of power feeding lines
- > Self-standing structure





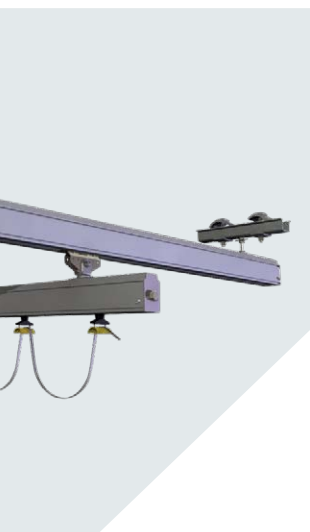

Size	Capacity (kg)	Dimensions (mm)	Weight (kg/m)
XA06	320	130*90	6,5
XA10	2000	215*100	10,5
XA14	2000	250*115	14,5

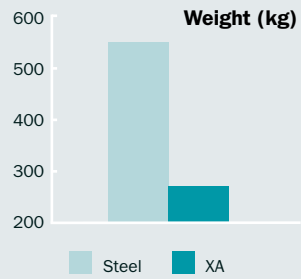

Weight of single girder suspension crane with SWL 2t - 15m runway - 4m span.

XA RANGE

Span (m)

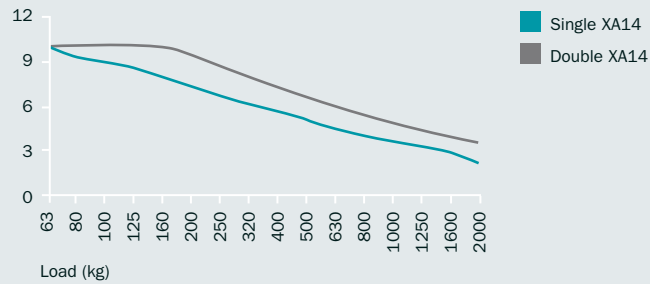

XA sets benchmark with aluminium cranes up to 2 tons.

MANUAL EFFORT

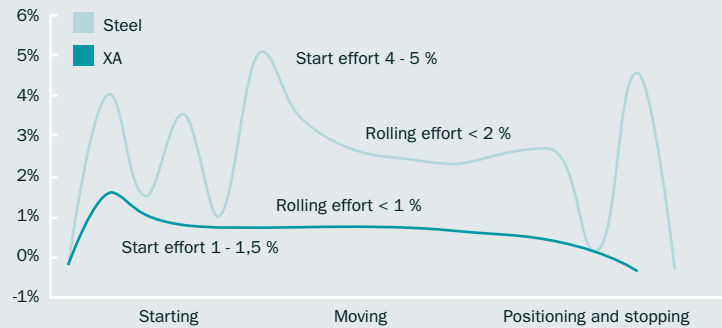

XA rolling resistance makes significant difference to steel – same load with less effort leads to better productivity.

Shorter page

REVOLUTIONARY PERFORMANCE OF XA LIGHT CRANE SYSTEMS:

Ergonomics

- > Less effort when operating, rolling resistance reduced by 50%, compared to traditional steel rails in the market
- > Low dead weight, reduced up to 50% compared to traditional steel rails in the market
- > High precision rail manufacturing process ensure smooth and silent movements, even across rail joints

Economics

- > Market leading spans due unique profile shape and high material strength, leading to bigger working area below crane
- > Thanks to outstanding suspension distance, less supporting structures are needed
- > Modular design makes short installation times possible, thus reducing downtime of crane and working area in question
- > Due to light weight and low rolling resistance, many applications can be realised with push/pull trolleys rather than motorised drives, thus providing cost-efficient modern solutions
- > Anodizing increases aluminium alloy's naturally excellent corrosion resistance and durability, allowing longer lifetime

Aesthetics

- > Create your modern working environment with the product of tomorrow

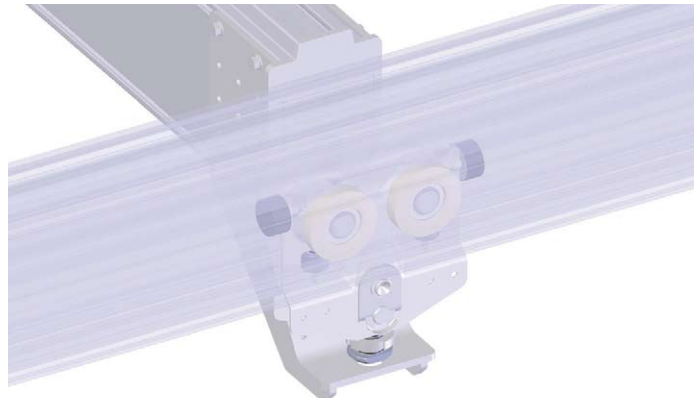

Three profile sizes.



SERVICE



LIGHT LIFTING



INDUSTRIAL CRANES



PROCESS CRANES



PORT CRANES



LIFT TRUCKS



Konecranes is a world-leading group of Lifting Businesses™, serving a broad range of customers, including manufacturing and process industries, shipyards, ports and terminals. Konecranes provides productivity-enhancing lifting solutions as well as services for lifting equipment and machine tools of all makes. In 2007, Group sales totaled EUR 1,750 million. The Group has 8,400 employees, at more than 470 locations in 43 countries. Konecranes is listed on the OMX Nordic Exchange Helsinki (symbol: KCR1V).

© 2008 Konecranes. All rights reserved. 'Konecranes', 'Lifting Businesses' and  are registered trademarks of Konecranes.



KONECRANES®



Konecranes Standard Lifting Corporation Vankaniälde 7 FI-13100 Hämeenlinna Finland
Tel +358(0)20427 11 Fax +358(0)20427 3599 www.konecranes.com